

MOLDING INSTALLATION

1. Install mouldings on a solid backing with studs or joists 16" on center or less. **NOTE: Large profiles require additional blocking.**

2. Mark the distance on the wall to be covered by the first piece of moulding. Oversize and cut the moulding, adding 1/8" for every 5 feet of moulding required.

Example: If the distance to be covered is 15', cut your moulding at 15' 3/8".

3. Run a bead of urethane adhesive along the top and bottom edge of the moulding where it will meet the backing.

4. Using galvanized screws, fasten one end of the moulding at your starting point. Pull the center of the moulding away from the wall, which will draw the free end of the moulding back to the 15' mark. Secure the free end of the moulding at the mark.

5. Push the center of the moulding flat to the surface. The moulding should snap into place. Secure with galvanized screws, 16" on center or less. If the moulding does not push flat, you need to unfasten one end and re-secure the moulding approximately 1/8" past your 15' mark.

6. For continuous long runs for mouldings.

A. Install the first piece using the procedure above.

B. For the second piece, follow steps 1 through 3.

C. Step 4 (above) anchors the end of the moulding on your mark. Then apply urethane adhesive to the end of the first piece, this will adjoin the next piece of moulding.

D. Butt the free end of the moulding to your first piece and follow step 5 to secure in place.

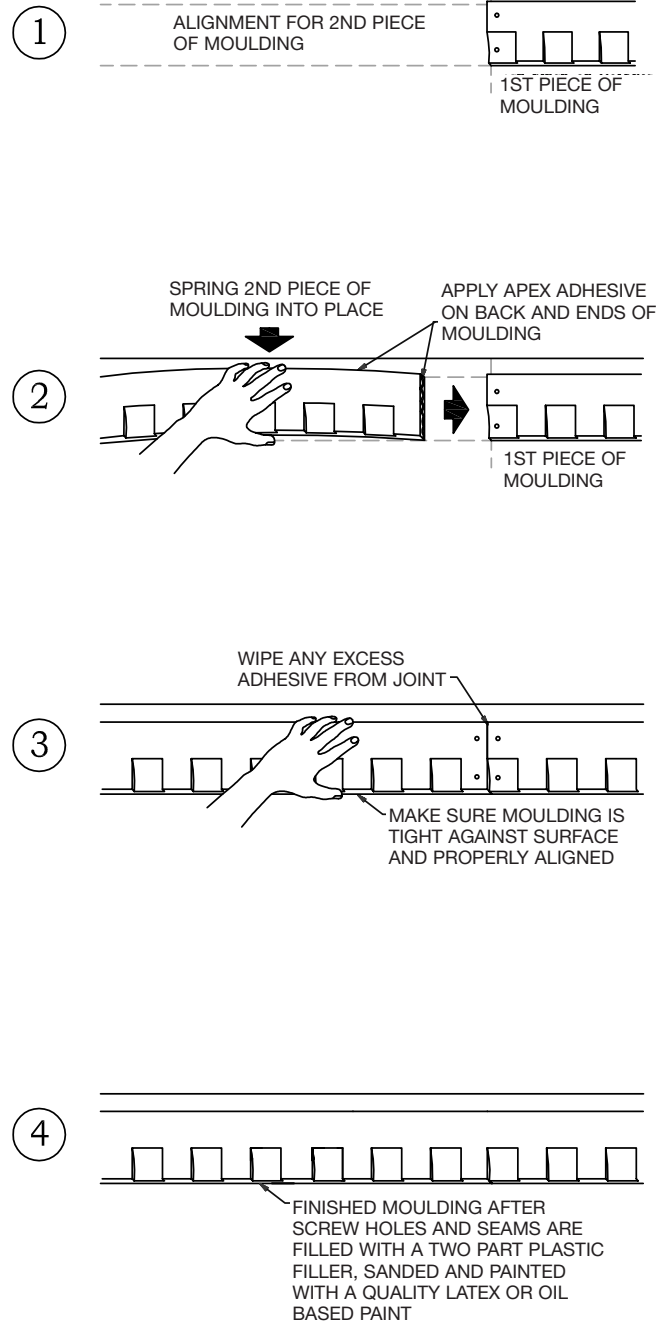

MITER BOX INSTRUCTIONS

1. Measure the height and projection of your molding. If you are using several large pieces of molding, work with your largest molding. Molding shown in drawing A1 is the correct way it must be placed in the miter box. (Molding is upside down).

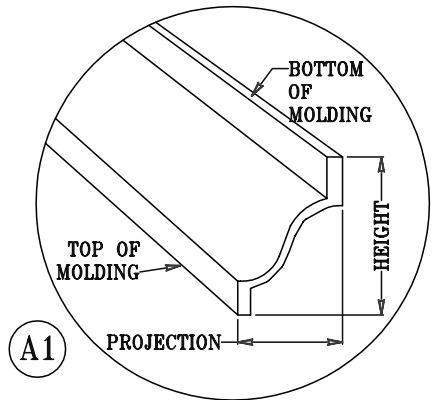
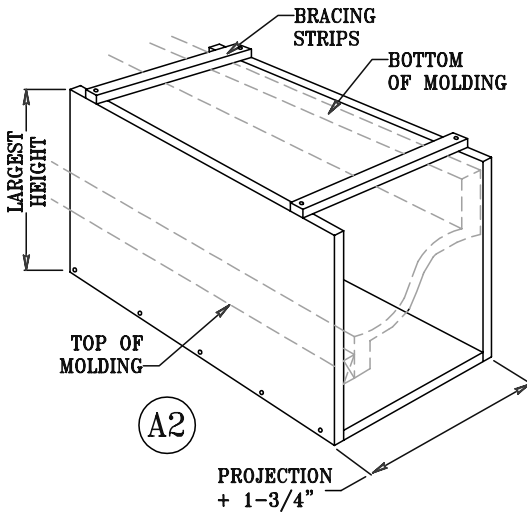

2. Using 3/4" plywood cut the bottom piece the depth of the largest molding projection you need to cut. If you need to cut a smaller molding you can use a removable block to hold it in place while cutting. Cut the sides slightly larger than the tallest molding. Cut two 1-1/2" strips and mount them on the top making sure that your sides are square with the bottom plate as shown in drawing A2.

3. Using a framing square mark out the angles you need to cut. Square your marks down the plywood side wall. With a hand saw cut your angle in the side wall, making sure you follow your line down, so your angle stays true. You are now ready to place your molding upside down in the box keeping the top of the molding flat against the bottom and the bottom of the molding tight against the side. See drawing A3.

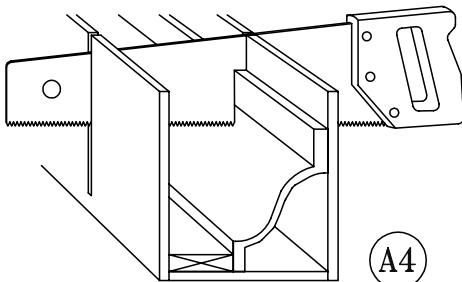
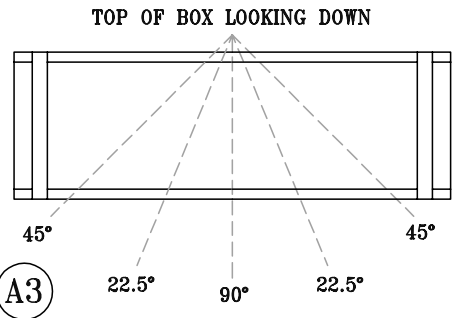

4. For smaller molding profiles measure the projection and mark the distance from the side wall of the miter box. Cut a piece of wood blocking to fill the space between the molding and the side wall. This will act as an edge to rest your molding against while cutting. See drawing A4.